



VOLTAGE

12V

CAPACITY (20H)

5,3 AH

CAPACITY (10H)

5 AH

CCA (EN)

65 A

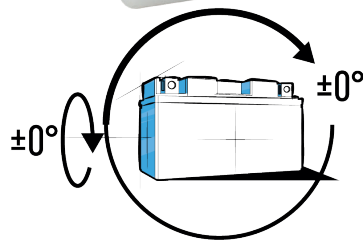

Upright inclinasion

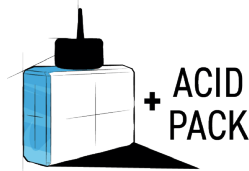

+ ACID PACK

DIMENSIONS & WEIGHT

Length (L):	120 mm ±2mm
Width (W):	61 mm ±2mm
Height (H):	130 mm ±2mm
Weight:	1,95 Kg

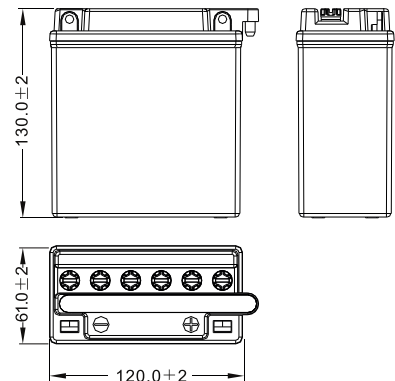

BENEFITS

- > **Activation before first use**  
Dry pre-charged battery
- > **Acid pack included**  
For initial filling
- > **Periodically Maintenance**  
Periodically topped up to maintain
- > **Reliable starting power**  
For vehicles with standard requirements
- > **Long shelf life**  
No recharge required before acid filling
- > **Wide variety of battery sizes**  
Including 6V & 12V versions

TERMINAL (mm)

