



## BLUE dynamic EFB

### Vehicle Key Benefits



Ready for entry-level start-stop systems



Engineered to the highest German standards



Patented PowerFrame® grid for reliable starting power, fast recharge and corrosion resistance.



Meets all original criteria of the car manufacturer

For more information visit [varta-automotive.com](http://varta-automotive.com)

### ORDER INFORMATION

European Type No. (ETN):	595500085
Article Number:	595500085D842
Short Code:	N95
Barcode:	4016987152331
UK Code:	019EFB
Packaging Unit:	1
Quantity per Pallet:	36

### TECHNICAL INFORMATION

Voltage [V]:	12	Base Hold-down:	B13
Battery Capacity [Ah]:	95	Layout:	0
Cold Cranking Amps (CCA), EN [A]:	850	Terminal Types:	1
Length [mm]:	353	Case Size:	H8/LN5
Width [mm]:	175	Weight filled (kg):	24,49
Height [mm]:	190		

# DRAWINGS

**B13**

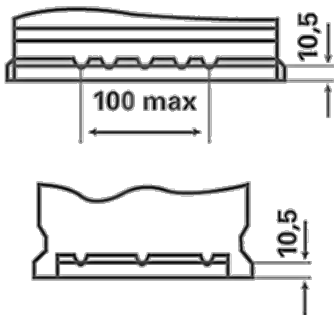

**0**

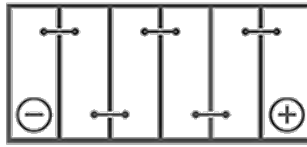

**1**

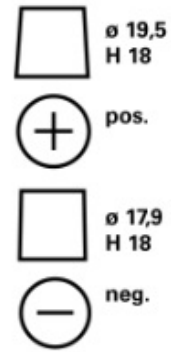

**3**

