

# TYPE 896CXT



## SPECIFICATIONS

VOLTAGE  
12V

AH  
32 AH

CCA (EN)  
310 CCA(EN)

PALLET QUANTITY  
140

LAYOUT  
1

BASE HOLDOWN  
B00

TERMINAL  
19

EAN CODE  
5060196061280

CASE TYPE  
U1

TERMINAL

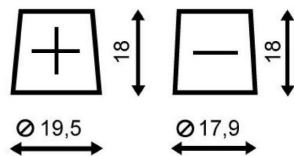

HOLDOWN



LAYOUT

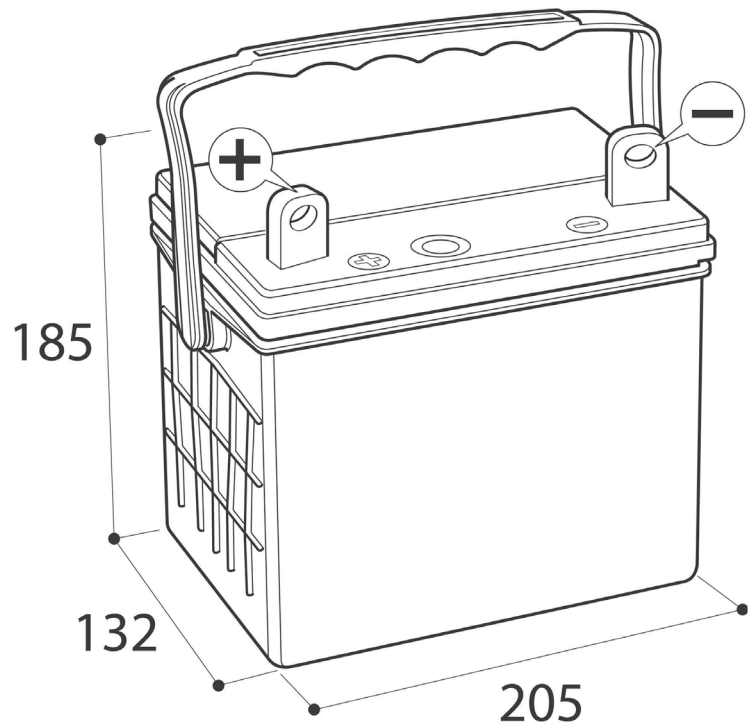
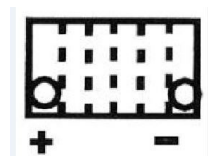

## DIMENSIONS

LENGTH	205 mm
WIDTH	132 mm
HEIGHT	185 mm
WEIGHT	7.6 kgs

## TRANSPORT INFORMATION

- Classified as "Batteries, Wet, Filled with Sulphuric Acid".
- UN2794
- Class 8
- Packing Group III