

TYPE XV27MF



SPECIFICATIONS

VOLTAGE

12V

AH

100 AH

CCA (EN)

720 CCA(EN)

PALLET QUANTITY

75

LAYOUT

1

BASE HOLDOWN

B01

TERMINAL

DT

EAN CODE

5060196060108

CASE TYPE

GRP27

TERMINAL

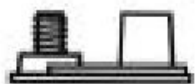

HOLDOWN

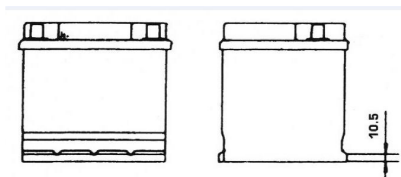

LAYOUT

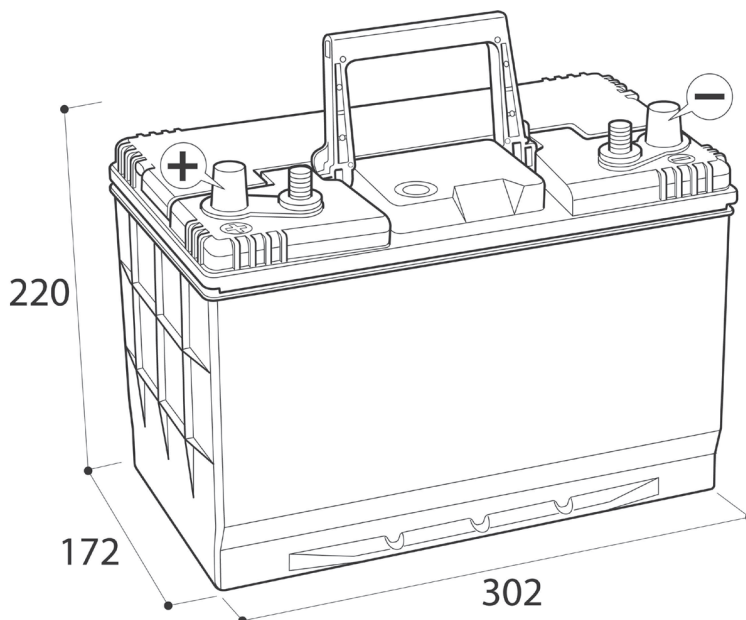
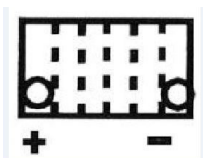

DIMENSIONS

LENGTH	302 mm
WIDTH	172 mm
HEIGHT	220 mm
WEIGHT	20.6 kgs

TRANSPORT INFORMATION

- Classified as "Batteries, Wet, Filled with Sulphuric Acid".
- UN2794
- Class 8
- Packing Group III