

TYPE XV24MF



SPECIFICATIONS

VOLTAGE

12V

AH

86 AH

CCA (EN)

720 CCA(EN)

PALLET QUANTITY

90

LAYOUT

1

BASE HOLDOWN

B01

TERMINAL

DT

EAN CODE

5060196060092

CASE TYPE

GRP24

TERMINAL

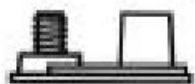

HOLDOWN

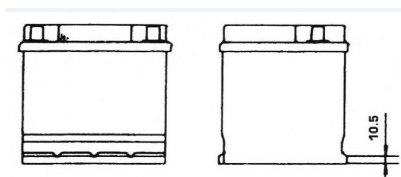

LAYOUT

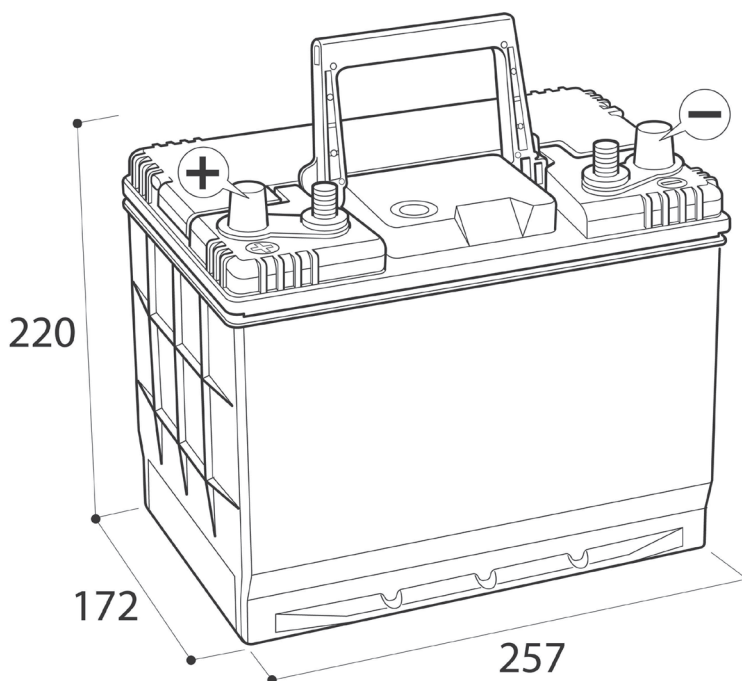
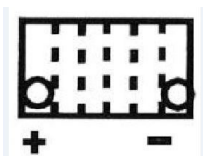

DIMENSIONS

LENGTH	257 mm
WIDTH	172 mm
HEIGHT	220 mm
WEIGHT	18.6 kgs

TRANSPORT INFORMATION

- Classified as "Batteries, Wet, Filled with Sulphuric Acid".
- UN2794
- Class 8
- Packing Group III