

# LSLA20-12

## Valve Regulated Lead Acid Rechargeable Battery

### Specifications

Nominal Voltage	12v
Capacity (20hr)	20.00AH
Capacity (10hr)	19.00AH
Weight	6.10kgs
Container Material	ABS

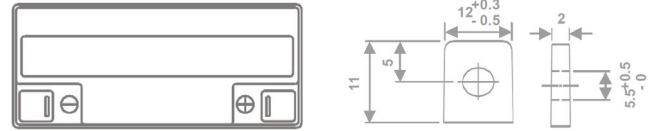

### Operating Temperature Range

Charge	-15°C-50°C
Discharge	-15°C-40°C
Storage	-15°C-40°C

### Charging Methods at 25°C

Cycle Use	14.40-15.00V
Co-efficient	-5mV/C
Standby Use	13.50-13.80V
Co-efficient	-3mV/C
Internal Resistance	10.0 mΩ
Self Discharge (per month)	3.6% PER MONTH AT 20°C AVERAGE
Max Discharge	300A(5s)

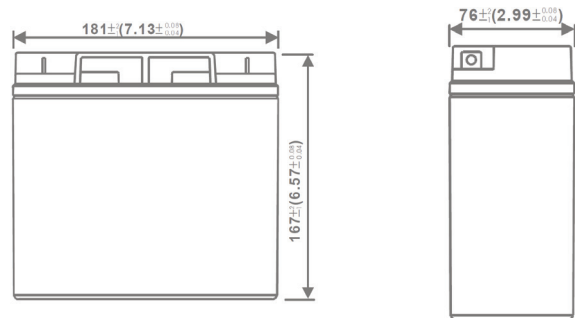

### Dimensions

Length	181.0mm
Width	76.0mm
Height	167.0mm
Total Height (inc. Terminal)	167.0mm

### Depth of Discharge Characteristics

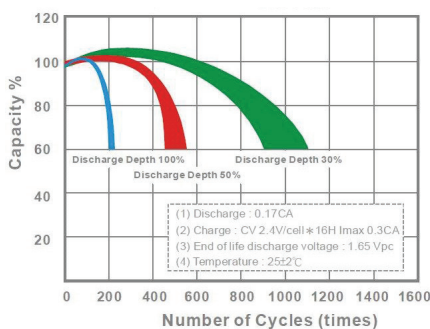

### Storage Characteristics

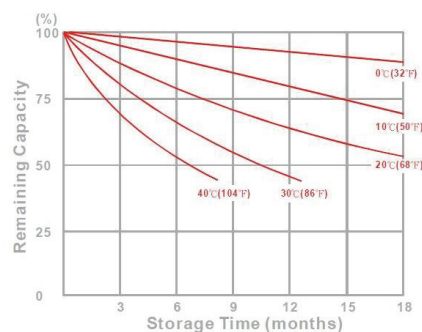

### Safety Information

Installation	Can be installed and operated in any orientation except permanently inverted
Handles	Batteries must not be left permanently suspended by their handles (where fitted)
Vent Valves	Each cell is fitted with a low pressure release valve to allow gases to escape then reseal
Gas Release	VRLA batteries release hydrogen gas which can form explosive mixtures in air - do not keep inside a sealed container
Recycling	VRLA batteries must be recycled at the end of their life in accordance with national laws

### Transport Information

- Classified as 'Batteries, wet, non-spillable, electric storage'
- UN2800
- Class 8
- Packaging Group III