

TYPE DC25MF



SPECIFICATIONS

VOLTAGE

12V

AH

105 AH

CCA (EN)

850 CCA(EN)

PALLET QUANTITY

36

LAYOUT

0

BASE HOLDDOWN

B13

TERMINAL

1

NCC CATAGORY

B

CASE TYPE

L5

TERMINAL

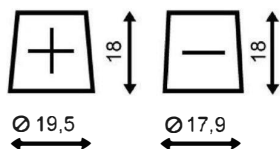

HOLDOWN



LAYOUT

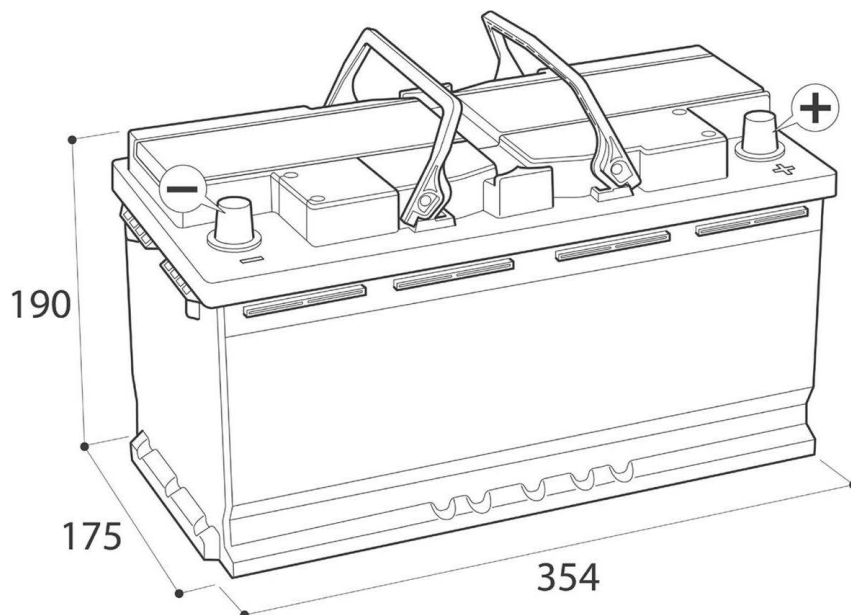
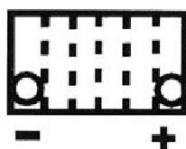

DIMENSIONS

LENGTH	354 mm
WIDTH	175 mm
HEIGHT	190 mm
WEIGHT	25.0 kgs

TRANSPORT INFORMATION

- Classified as "Batteries, Wet, Filled with Sulphuric Acid".
- UN2794
- Class 8
- Packing Group III