

# TYPE XV31MF



## SPECIFICATIONS

VOLTAGE  
12V

AH  
105 AH

CCA (EN)  
740 CCA(EN)

PALLET QUANTITY  
48

LAYOUT  
1

BASE HOLDOWN  
B01

TERMINAL  
DT

EAN CODE  
5060196060115

CASE TYPE  
GRP31

TERMINAL

5/16 " -18 Threads



HOLDOWN

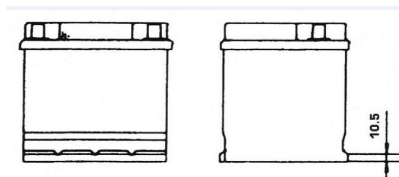

LAYOUT

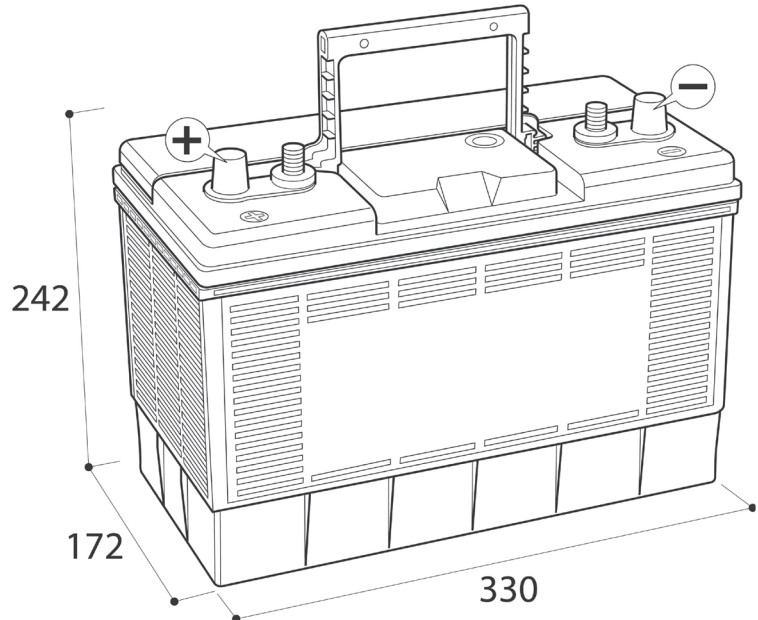
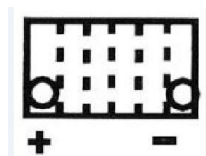

## DIMENSIONS

LENGTH	330 mm
WIDTH	172 mm
HEIGHT	242 mm
WEIGHT	23.0 kgs

## TRANSPORT INFORMATION

- Classified as "Batteries, Wet, Filled with Sulphuric Acid".
- UN2794
- Class 8
- Packing Group III