

# TYPE XDC25AGM



## SPECIFICATIONS

### VOLTAGE

12V

### AH

95 AH

### CCA (EN)

850

### PALLET QUANTITY

36

### LAYOUT

0

### BASE HOLDOWN

B01

### TERMINAL

Standard

### NCC CATAGORY

### CASE TYPE

L5

### TERMINAL

### HOLDOWN

### LAYOUT

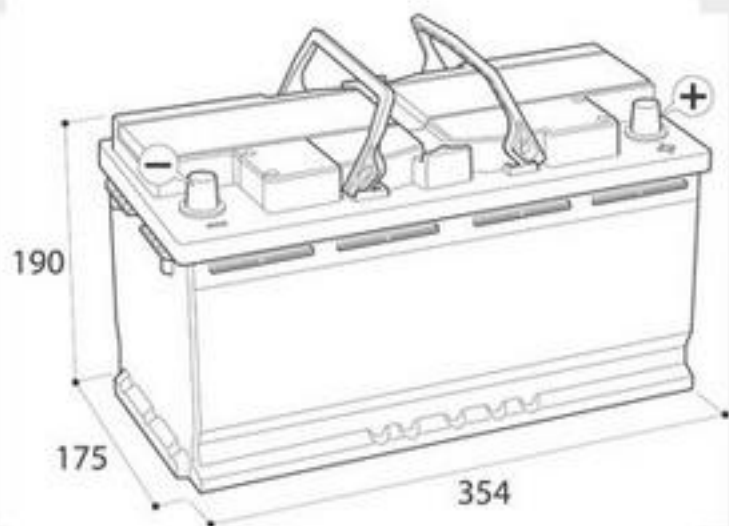

## DIMENSIONS

LENGTH	354 mm
WIDTH	175 mm
HEIGHT	190 mm
WEIGHT	25.9kgs

## TRANSPORT INFORMATION

- Classified as "Batteries, Wet, Filled with Sulphuric Acid".
- UN2794
- Class 8
- Packing Group III

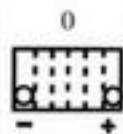
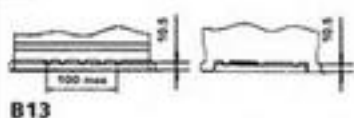
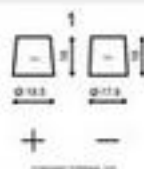

**NUMAX**



Manbat Ltd, Lancaster House, Lancaster Road, Shrewsbury SY1 3NJ • [www.manbat.co.uk](http://www.manbat.co.uk)  
• [sales@manbat.co.uk](mailto:sales@manbat.co.uk)